

SHELL TYPE NEEDLE ROLLER BEARINGS

Inch Series



Shaft dia. 23.812 – 26.988mm

Shaft dia. mm (inch)	Identification number									
	Standard	Mass (Ref.) g	Closed end	Mass (Ref.) g	Standard	Mass (Ref.) g	Closed end	Mass (Ref.) g	Grease retained	Mass (Ref.) g
23.812 (15/16)	BA 158 Z	16.5	BAM 158	19	—	—	—	—	—	—
	BA 1510 Z	20.5	BAM 1510	23	—	—	—	—	—	—
	BA 1516 Z	33	BAM 1516	35.5	—	—	—	—	—	—
25.400 (1)	BA 166 Z	13.1	BAM 166	16	—	—	—	—	—	—
	BA 167 Z	15.4	BAM 167	18.3	—	—	—	—	—	—
	BA 168 Z	17.7	BAM 168	20.5	—	—	—	—	—	—
	BA 1610 Z	22	BAM 1610	25	—	—	—	—	—	—
	BA 1612 Z	26.5	BAM 1612	29.5	—	—	—	—	—	—
	BA 1614 Z	31	BAM 1614	33.5	—	—	—	—	—	—
	BA 1616 Z	35.5	BAM 1616	38	—	—	—	—	—	—
	BA 1620 Z	44	BAM 1620	46.5	—	—	—	—	—	—
	—	—	—	—	—	—	—	—	YB 168	23
	—	—	—	—	—	—	—	—	YB 1612	34.5
	—	—	—	—	—	—	—	—	YB 1616	46.5
	—	—	—	—	BHA 168 Z	24	BHAM 168	27	—	—
	—	—	—	—	BHA 1610 Z	28	BHAM 1610	31	—	—
	—	—	—	—	BHA 1612 Z	33.5	BHAM 1612	37	—	—
	—	—	—	—	BHA 1614 Z	39.5	BHAM 1614	42.5	—	—
	—	—	—	—	BHA 1616 Z	45	BHAM 1616	48	—	—
	—	—	—	—	BHA 1620 Z	56.5	BHAM 1620	59.5	—	—
	—	—	—	—	BHA 1624 Z	67.5	BHAM 1624	71	—	—
—	—	—	—	—	—	—	—	YBH 168	29	
—	—	—	—	—	—	—	—	YBH 1612	44.5	
—	—	—	—	—	—	—	—	YBH 1616	59.5	
26.988 (1 1/16)	BA 1710 Z	23.5	BAM 1710	26.5	—	—	—	—	—	—
	BA 1716 Z	37	BAM 1716	40.5	—	—	—	—	—	—

Note(1) Allowable rotational speed applies to oil lubrication. For grease lubrication, a maximum of 60% of this value is allowable.  
 Remark Shell Type Grease Retained Full Complement Needle Roller Bearings are provided with prepacked grease. Standard type and closed end type bearings are not provided with prepacked grease, so perform proper lubrication when using these types of bearings.

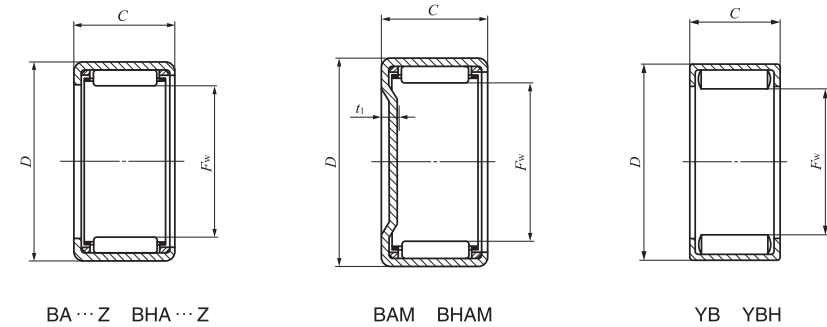

Boundary dimensions mm(inch)				Standard mounting dimensions mm				Basic dynamic load rating C N	Basic static load rating C <sub>0</sub> N	Allowable rotational speed <sup>(1)</sup> min <sup>-1</sup>	Assembled inner ring				
F <sub>w</sub>	D	C	t <sub>1</sub> Max.	Shaft dia. h6 Max. Min.		Housing bore dia. J7 Max. Min.									
23.812 (15/16)	30.162 (1 3/16)	12.70 (.500)	2.8	23.812	23.799	30.176	30.151	8 000	11 400	16 000	—				
23.812 (15/16)	30.162 (1 3/16)	15.88 (.625)	2.8					11 000	17 100	16 000	IRB 1110				
23.812 (15/16)	30.162 (1 3/16)	25.40(1.000)	2.8					18 900	34 300	16 000	IRB 1116				
25.400 (1)	31.750 (1 1/4)	9.52 (.375)	2.8	25.400	25.387	31.764	31.739	6 010	8 020	15 000	—				
25.400 (1)	31.750 (1 1/4)	11.13 (.438)	2.8					7 720	11 100	15 000	—				
25.400 (1)	31.750 (1 1/4)	12.70 (.500)	2.8					8 240	12 000	15 000	IRB 128				
25.400 (1)	31.750 (1 1/4)	15.88 (.625)	2.8					11 300	18 100	15 000	—				
25.400 (1)	31.750 (1 1/4)	19.05 (.750)	2.8					14 200	24 300	15 000	IRB 1212				
25.400 (1)	31.750 (1 1/4)	22.22 (.875)	2.8					16 900	30 400	15 000	IRB 1214				
25.400 (1)	31.750 (1 1/4)	25.40(1.000)	2.8					19 400	36 300	15 000	IRB 1216				
25.400 (1)	31.750 (1 1/4)	31.75(1.250)	2.8					24 400	48 500	15 000	IRB 1220				
25.400 (1)	31.750 (1 1/4)	12.70 (.500)	—					19 400	36 000	6 000	IRB 128				
25.400 (1)	31.750 (1 1/4)	19.05 (.750)	—					28 200	58 000	6 000	IRB 1212				
25.400 (1)	31.750 (1 1/4)	25.40(1.000)	—					36 300	80 300	6 000	IRB 1216				
25.400 (1)	33.338 (1 5/16)	12.70 (.500)	3.4					25.400	25.387	33.352	33.327	10 200	13 100	15 000	IRB 128
25.400 (1)	33.338 (1 5/16)	15.88 (.625)	3.4									15 300	22 100	15 000	—
25.400 (1)	33.338 (1 5/16)	19.05 (.750)	3.4									19 300	29 700	15 000	IRB 1212
25.400 (1)	33.338 (1 5/16)	22.22 (.875)	3.4									23 000	37 200	15 000	IRB 1214
25.400 (1)	33.338 (1 5/16)	25.40(1.000)	3.4									26 400	44 500	15 000	IRB 1216
25.400 (1)	33.338 (1 5/16)	31.75(1.250)	3.4									33 200	59 600	15 000	IRB 1220
25.400 (1)	33.338 (1 5/16)	38.10(1.500)	3.4									39 400	74 400	15 000	—
25.400 (1)	33.338 (1 5/16)	12.70 (.500)	—	20 900	34 100	6 000	IRB 128								
25.400 (1)	33.338 (1 5/16)	19.05 (.750)	—	30 700	56 100	6 000	IRB 1212								
25.400 (1)	33.338 (1 5/16)	25.40(1.000)	—	39 900	78 400	6 000	IRB 1216								
26.988 (1 1/16)	33.338 (1 5/16)	15.88 (.625)	2.8	26.988	26.975	33.352	33.327					11 600	19 200	14 000	—
26.988 (1 1/16)	33.338 (1 5/16)	25.40(1.000)	2.8	—	—	—	—					20 000	38 300	14 000	—